

DV-VR01-072

HIGH SECURITY ACCESSIBLE TOILET

KWC DVS

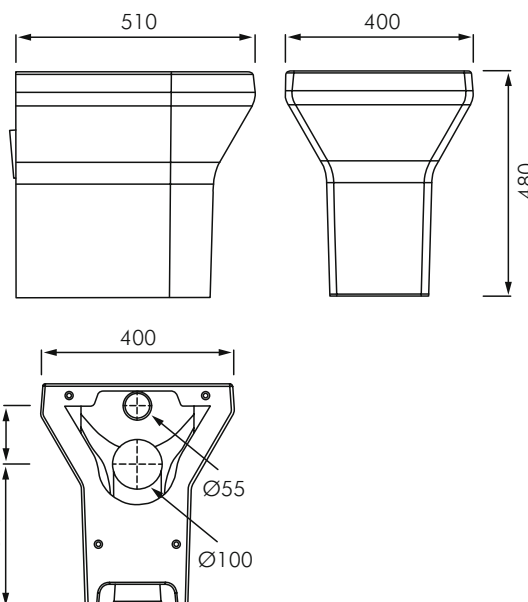

DESCRIPTION

The KWC DVS DV-VR01-072 is a raised height high security toilet pan designed and tested to be vandal-proof and avoid ligature points wherever possible. A high-grade non-porous polyester gel coat surface in all white with moulded grey seat rim comes as standard. The gel coat has been specially formulated to resist chemicals and ultraviolet rays.

In it's standard format this raised height WC is suitable for use in assisted care bathrooms, providing easier use by the elderly, however it can be extended in length using the DV-VR01-012 extension box fully meeting the requirements of AS1428 accessible bathroom requirements.

Features include water efficient 4.5L flush, domestic aesthetics, moulded impact resistant construction, vandal and ligature resistant.

The WC is designed for through wall mounting where there is a duct directly behind the fixture. It is supplied with 4 only 12 xmm stainless steel fixing rods as standard. Where there is no duct, an inwall fixing bracket is available.

Ideal for use in applications requiring a high degree of vandalism protection including prisons and mental health facilities.

INSTALLATION

- Floor/through wall mounted.
- 4.5L flush meeting WELS 4 Star performance requirements.
- P trap only.
- Fixing kit for walls up to 250mm thick included.
- Optional inwall mounting bracket, used where there is no duct directly behind WC (must have access panel above WC for waste/water connection).

MODELS

- DV-VR01-011** - Standard accessible toilet with moulded grey seat rim
- DV-VR01-012** - 235mm extension box for AS1428 accessible toilet

OPTIONS

- DV-VR01-UWB** - Inwall mounting bracket to suit DV-VR01-010 & DV-VR01-011 toilets

